



## WHEEL LOADER | 419S

Gross engine power: 145kW (195hp) Operating weight: 10,998kg Full turn tipping load: 7,716kg Standard shovel capacity: 1.6m<sup>3</sup>





# LOADS MORE POWER

The JCB 419S, one powerful member of the Agri S range has just got loads more. The new 419S has a Stage V Cummins 6.7 litre engine, producing an impressive performance with a massive 145kW (195hp) of power; up 6% on our previous model, and 881Nm of torque; up 5%. It also weighs under 11 tonnes giving it a huge power to weight ratio. And with unbeatable cab comfort and visibility, the new 419S is one highly productive machine, capable of tackling most jobs on any size farm.

STAGE V









# LOADS MORE QUALITY.

WE KNOW THAT A WHEEL LOADER IS A KEY PART OF ANY FARM'S PROCESS. THAT'S WHY WE'VE BUILT IN LOADS MORE QUALITY AND RELIABILITY INTO THE NEW JCB 419S. THE PROCESSES WE'VE USED TO DESIGN, TEST AND MANUFACTURE THEM WILL SAFEGUARD YOUR WORKING PROCESS, HOUR AFTER HOUR, DAY AFTER DAY.

The front chassis is more durable than ever; it's been strengthened with additional ribs and gussets for maximum service life.



## Designed to work harder.

**1** Your new 419S will have benefitted from finite element analysis and rig testing of up to 1 million cycles, to ensure superior structural strength and durability. For further peace of mind, cold cell testing guarantees starting performance down to -20 degrees.

**2** High tolerances and accurate location of pins and bushes are guaranteed with JCB's precision machining techniques.

**3** State-of-the-art manufacturing processes like robot machining, precision paint technology and innovative assembly techniques help to achieve the very highest levels of build quality.



## Built to last.

**4** A solid cast rear counterweight protects the rear of your 419S - including the rear lights and cooling pack - from damage.

For additional protection, there are impact resistant fender edges and trims fitted.

**5** Hoses are neatly routed and clamped through the articulation joint, well away from any pinch points.

**6** Designed to tolerate both vertical and horizontal loadings, the articulation joint has a heavy-duty centre pin and oversized bush, as well as twin taper roller bearings on the top box joints.

**7** The 419S has integral steel fluid tanks for the ultimate in leak protection; a far superior solution to the plastic tanks favoured by some competitors.

**8** New cooling pack sealing and mudguard fitment for greater overall quality.





# LOADS MORE PRODUCTIVITY.

THE 419S CAN PERFORM GREAT FEATS OF PRODUCTIVITY. DELIVERING A MASSIVE 195HP, AND WEIGHING UNDER 11 TONNES, THE MACHINE HAS A HUGE POWER-TO-WEIGHT RATIO OF 17.7HP/TONNE FOR ULTIMATE PUSHING, CLIMBING AND ROADING PERFORMANCE.

## Powering it all.

- 1 The Cummins B 6.7 litre engine achieves maximum engine power (145kW) and peak torque (881Nm) at low revs for excellent response.
- 2 A variable geometry turbocharger provides increased performance at low engine speed for improved cycle times and tractive effort.
- 3 JCB's optional quickhitch makes attachment changing quick and efficient. The quickhitch is designed to be compatible with aftermarket attachments too.
- 4 Powerful single variable displacement piston pump hydraulics can circulate an incredible 180 l/min for fast cycle and excellent multi-function capability.

Optional 10 tonnes hydraulic or mechanical tow hitch with hydraulic trailer brakes and 12V trailer electrics further improve versatility on the 419S.

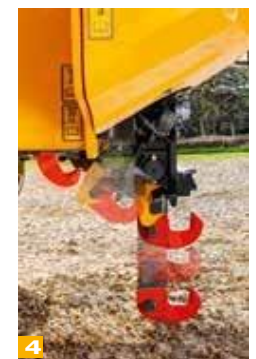



## Loading productivity

5 The high torque (HT) arm design on the 419S gives greater visibility to the loader end, as well as offering parallel lift, making it ideal for multi-attachment use. Constant torque throughout the full carriage rotation provides excellent power and attachment control. Choose a HT high lift on the 419S and you can use the machine for higher loading height applications (hopper, trailer and spreader loading).

With maximum breakout forces of 93kN, this wheel loader has the power to carry out extremely arduous jobs.

## Drivetrain productivity

6 The unique 6-speed transmission with torque convertor lock-up in every gear provides closer gear ratios for better acceleration, hill climbing and roading performance. The lock-up element eliminates losses from the torque converter for faster cycle times and improved efficiency.

7 With a choice of axle options you can tailor a 419S to any application.

› Limited slip differential is perfect for soft, muddy terrain, with reduced traction.

› Open differentials with an automatic locking front axle differential provide excellent traction in varied ground conditions - ideal for straight line pushing.

The innovative electronic management system can perform progressive clutch cut-off for efficient, productive loader control. This feature governs tractive effort via the transmission, diverting maximum power to the loader hydraulics whilst reducing service brake wear and fuel consumption.



### COMMANDPLUS controls.

A choice of 3 or 4-spool hydraulics gives you the scope for invaluable extra versatility. Flow can be adjusted from the cab via the all-new CommandPlus controls.



4 HT Standard Lift

HT High Lift



6

## LOADS MORE EFFICIENCY.

THE JCB 419S IS DESIGNED TO MOVE MORE MATERIAL FOR LESS. TO ACHIEVE THIS, WE'VE DESIGNED THE ENGINE, AXLES, DRIVELINE AND HYDRAULICS TO WORK IN HARMONY WITH EACH OTHER, FOR ULTIMATE EFFICIENCY.



Automatic idle returns the engine to 700rpm after 30 seconds of inactivity.

### Driving efficiency.

1 The new JCB 419S' Stage V Cummins engine offers you plenty of low-end torque and maintains it over a wide engine speed range.

2 A hydraulic cooling fan automatically reacts to ambient temperature and adjusts the fan speed to optimise energy and reduce fuel consumption. An additional benefit of this setup is reduced noise levels.

3 Two new power modes at the flick of a switch. Standard Mode reduces engine power by 26% for light duty work to 144hp, helping to conserve fuel. Dynamic Mode increases power to a maximum 195hp for greater output.





**COMMANDPLUS controls.**  
 JCB's Smoothride load suspension limits shock loadings and therefore reduces material spillage and structural stress, as well as increasing operator comfort. The speed of engagement is adjustable from within the cab using the latest state-of-the-art CommandPlus controls.

A new auto engine shutdown feature saves fuel by switching off the engine when the machine is left idling. Idle time can be set by the operator from the cab seat.

5 Wheel speed braking means the brakes on the new 419S rotate at the same speed as the wheels, for heat and drag reduction plus improved fuel economy.

6 Unloaded spool valves in the valve block allow the arms to lower under gravitation rather than hydraulic force; this reduces fuel consumption further still.

7 Selectable loader arm detents let operators control loader arm height limitations, return to dig settings and float functions, improving safety and productivity.



JCB's innovative variable displacement pump feeds a load-sensing valve block which only consumes power on demand, providing precise, efficient loader control.



Adjustable SRS engagement speed.

Adjustable Auxiliary control.

Adjustable reversing fan intervals.



6



7



## LOADS MORE COMFORT.

THE JCB COMMANDPLUS CAB IS ONE OF THE BEST CABS ON THE MARKET, WITH THE LATEST IN ERGONOMIC DESIGN PROVIDING AN OPTIMAL CONTROL LAYOUT AND DRIVER POSITION. THIS GIVES LOADS MORE COMFORT AND VISIBILITY, ENABLING EVEN GREATER OPERATOR PRODUCTIVITY.

The 419S has two full colour LCD screens to navigate your operating menus, with one doubling as a monitor for the rear view camera. For even greater operator comfort, the 419S is equipped with end damped steering for smoother steering from lock to lock.



### See the difference.

- 1** The B-pillars are positioned at the same width to the rear of the cab, providing a large interior with a superb panoramic front windscreen. All switches and auxiliary controls are located on the right-hand side B-pillar for easier access.
- 2** Using the simple, dedicated menu interface on the 419S is easily done with the intuitive rotary controller.
- 3** Controlling the loader is easy as all the controls are seat-mounted and therefore move with the seat suspension. Simply select the control system that's best for your operators; we offer single lever joystick or multi-lever configurations.





The noise level in the cab is an incredibly low 68dB(a): so quiet you can hardly hear the engine running.



To keep the operator environment comfortable to work in at all times, we've positively pressurised the cab to eliminate dust and fumes.

5 After extensive research into operator ergonomics, we've devised the Command Driving Position, which provides the most optimal control layout for a multitude of different driver shapes and sizes. You can also choose from an air suspension standard seat to a super deluxe half leather seat, featuring fully adjustable heating and cooling functionality, electrically adjustable lumbar support and adjustable dampers.

6 A set and forget feature makes operator access even easier by storing your preferred steering wheel position. It can be instantly returned to, even after you've folded the wheel away.

Specify your new 419S with either air conditioning or automatic climate control to create perfect working temperatures.

With a dedicated media port on board, you can be assured of superb connectivity for all of your electronic devices.

A sliding window on both sides of the cab allows easy communication with people outside the machine.

The electronic handbrake offers numerous advantages: it's quick and easy to operate, and, because there's no cable, there are fewer holes in the cab. This helps to isolate the operator environment further.



5



6



## LOADS MORE S APPEAL.

THE JCB AGRI S RANGE HAS BECOME A MUCH LOVED PREMIUM BRAND IN ITS OWN RIGHT. A BRAND THAT'S SYNONYMOUS WITH SUPERIOR PERFORMANCE AND STYLE; THE MACHINES TO HAVE. AND IN RECOGNITION OF THAT, WE'RE MAKING THEM EVEN MORE PERSONALISED AND SOUGHT AFTER. WE'VE ADDED LOADS MORE BRANDING AND STYLISH TOUCHES THROUGHOUT THE MACHINES TO MAKE YOU EVEN MORE PROUD TO OWN ONE.









## LOADS MORE UPTIME.

WHEEL LOADERS NEED TO SPEND THE MAXIMUM AMOUNT OF TIME DOING LOADS MORE WORK. WE'VE DESIGNED THE NEW 419S TO DO JUST THAT, WITH LONG SERVICE INTERVALS AND QUALITY COMPONENTS.

### Routine maintenance.

**1** It's easy to get to the engine on a new JCB 419S with a large opening single-piece bonnet.



**2** Accessing the diesel and DEF (Diesel Exhaust Fluid) tanks is also straightforward, via the lockable grille at the rear of the machine. You can also check washer fluid level, engine oil and coolant from inside the cab, with all other routine checks and grease points located at ground level. This makes life both easier and safer.



**3** The standard widecore cooling package is a large, single-faced unit so you can be assured of quick, easy and safe cleaning.

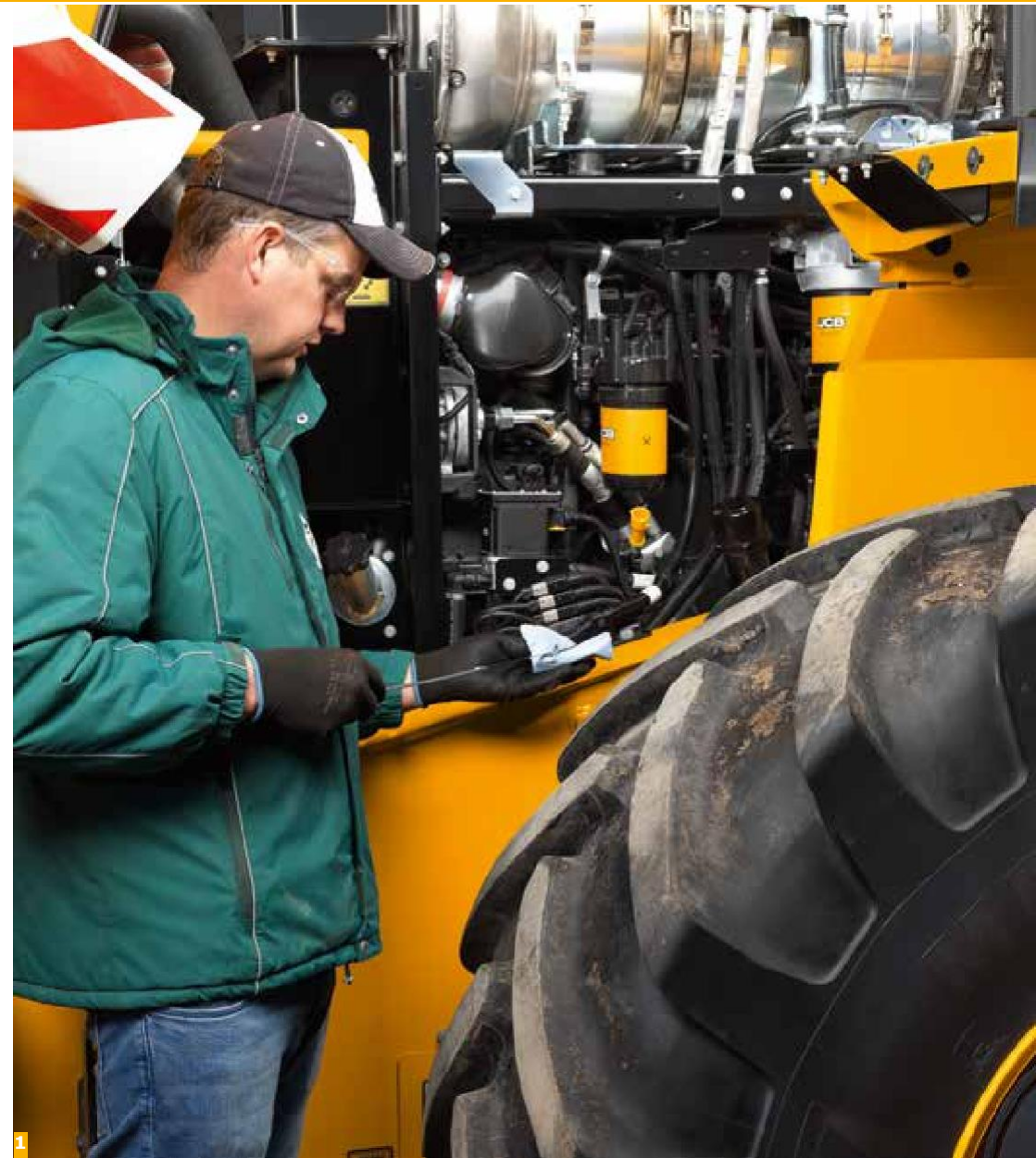



### Less servicing, more service.

**5** The CommandPlus cab relays machine condition with real-time alerts, safeguarding both the machine and the operator.

**6** The intuitive CommandPlus help function provides the operator with meaningful descriptions of in-cab switch functions. Using the “?” button allows new or unfamiliar operators to quickly and easily understand them without having to refer to the operator’s manual.

**7** By using premium components: Cummins engine, ZF transmission and axles, Rexroth pump and Husco valve block, we’ve built in long service life as standard.

Full hydraulic dual circuit braking with multiple oil immersed discs gives the braking system a virtually maintenance-free lifespan.

**8** A cyclonic engine fan scavenge filter provides four times the filtering capacity of a standard air filter. Its longer life system has fewer components and a higher level of efficiency, making for better engine protection.

Heating and ventilation filters are conveniently located behind an external access panel. The main fuse board and relays have been repositioned next to the door for easy access.





## LOADS MORE SAFETY.

THE NEW JCB 419S IS DESIGNED TO KEEP THE OPERATOR AND YOUR FARM SAFE AT ALL TIMES. GREATER VISIBILITY, NON-SLIP SURFACES AND FULL ROPS/FOPS PROTECTION ARE JUST THE START.

### Greater visibility.

- 1 Our rear-view camera displays an unobstructed rearward view on the in-cab colour monitor onboard your 419S. Interior mirrors, electrical adjustable heated exterior mirrors and rear camera combine to offer excellent views to every corner of your machine.
- 2 Superb visibility in dark conditions is guaranteed with JCB's optional 360 degree LED lighting.
- 3 Access steps are inclined and equally spaced, complemented by well positioned grab handles for three points of contact at all times.
- 4 New fully customisable automatic worklights engage when reverse is selected. The new headlight assist feature allows operators to automatically turn on the roof worklights for added visibility when working at night.





### Safely does it.

- 4 The front fender flaps have been carefully designed and honed to keep forward spray to a minimum. This increases safety and decreases debris build-up.
- 5 The new 419S' cab is isolator-mounted, compliant with ROPS/FOPS standards and positively pressurised against dust. You can choose from fresh air and carbon recirculation filters as well.
- 6 Visibility over the rear bonnet is excellent because the air cleaner is underneath the bonnet and the exhaust stack is located centrally.
- 7 Door hinges are mounted on the B-pillar; giving much better access via a larger and wider door aperture. It also means you can access the rear of your loader more safely.





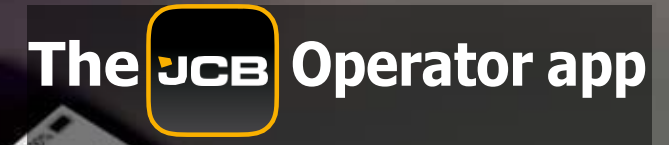

## LIVELINK TELEMATICS.

LiveLink telematics helps you monitor and manage your machine fleet remotely anywhere in the world by radically improving the efficiency, productivity, safety and security of all your JCB and non JCB machine fleet.

**MACHINE EFFICIENCY:** Keep track of your machine's daily activity with regular performance reports which provide information about idle time, location, machine health, error codes for diagnostics, engine utilisation by power band, safety alerts, and fuel consumption. JCB LiveLink ensures machines are kept running for maximum uptime and return on investment.

**MACHINE RELIABILITY:** Accurate hours and service alerts improve maintenance planning to optimise machine productivity.

**MACHINE SECURITY:** LiveLink's real time geo-fencing alerts tell you when machines move out of predetermined zones. Curfew alerts inform you of unauthorised usage.



Track the location of any asset via Bluetooth connection.



An after market telematics solution which can be retrofitted to any machine.

## COMPLETE CONTROL FOR YOUR FLEET.

LiveLink Fleet enables you to track every aspect of your equipment to maximise efficiency and machine uptime.

**GUESS LESS, KNOW MORE:** Equipment issues and service reminders are logged as soon as they occur, helping you to react quickly.

**YOUR EYES ON THE GROUND:** Integrate LiveLink Fleet with the JCB Operator mobile app and data from your operators' daily equipment checks feed instantly into your dashboard.

**TOTAL PEACE OF MIND:** Operator safety alerts help to ensure machines are being used efficiently and safely.

**SMARTER TOOLS. SMARTER DECISIONS:** From hours worked to fuel wastage, access custom analytics on your fleet to make smarter decisions, quicker.

**EFFORTLESS MEETS PAPERLESS:** Access certificates, warranty information, quick start machine guides and manuals.

## THEY SPOT IT, YOU KNOW IT.

The JCB Operator app gives you faster, clearer and more accurate information about your fleet, direct from the people using your equipment each day.

**STAY IN TOUCH:** Get regular checks on your machine with visibility in the LiveLink Fleet portal.

**TAILOR YOUR CHECKS:** Customise your checklists to suit any application, customer or site.

**UPLOAD TO KEEP UPDATED:** Upload useful information with photos and comments.

**FULLY COMPATIBLE:** The JCB Operator app works with non telemetry related machines and assets.

**ACCESS ALL INFORMATION:** Get access to documentation such as quick start guides.

\*The individual features of LiveLink Telematics, LiveLink Fleet and Operator App vary per region, engine and machine type.



## FULLY SUPPORTED.

JCB'S WORLDWIDE CUSTOMER SUPPORT IS FIRST CLASS. WHATEVER YOU NEED AND WHEREVER YOU ARE, WE'LL BE AVAILABLE QUICKLY AND EFFICIENTLY TO HELP MAKE SURE YOUR MACHINERY IS PERFORMING TO ITS FULL POTENTIAL.



**1** Our Technical Support Service provides instant access to factory expertise, day or night, while our Finance and Insurance teams are always on hand to provide fast, flexible, competitive quotes.

**2** The global network of JCB Parts Centres is another model of efficiency; with 18 regional bases, we can deliver around 95% of all parts anywhere in the world within 24 hours. Our genuine JCB parts are designed to work in perfect harmony with your machine for optimum performance and productivity.

*Note: JCB LIVELINK and JCB extended warranty packages may not be available in your region, so please check with your local dealer.*



**3** JCB offers comprehensive extended warranties as well as service-only or repair and maintenance contracts. Irrespective of what you opt for, our Maintenance teams around the world charge competitive labour rates, and offer non-obligation quotations as well as fast, efficient insurance repair work.

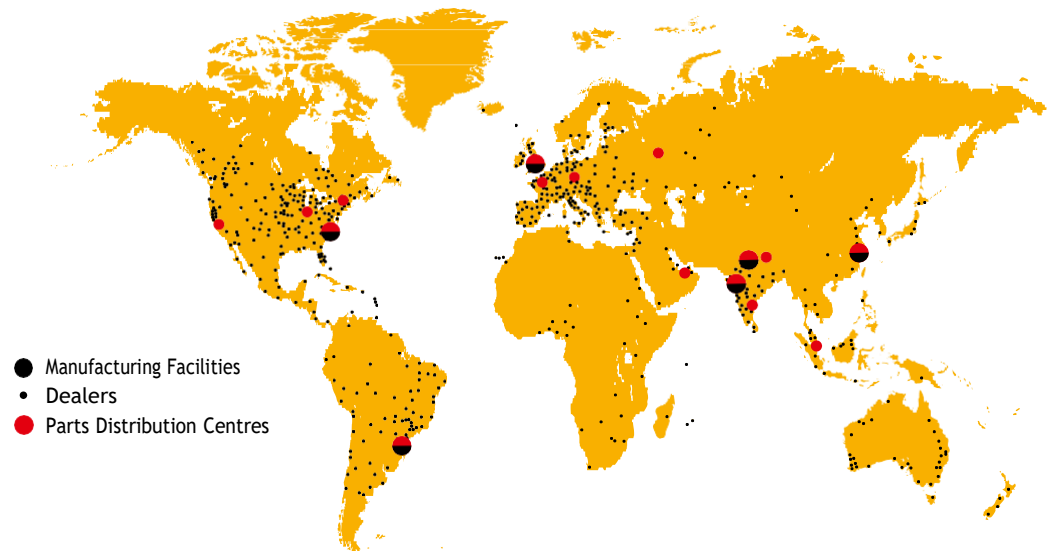



STATIC DIMENSIONS

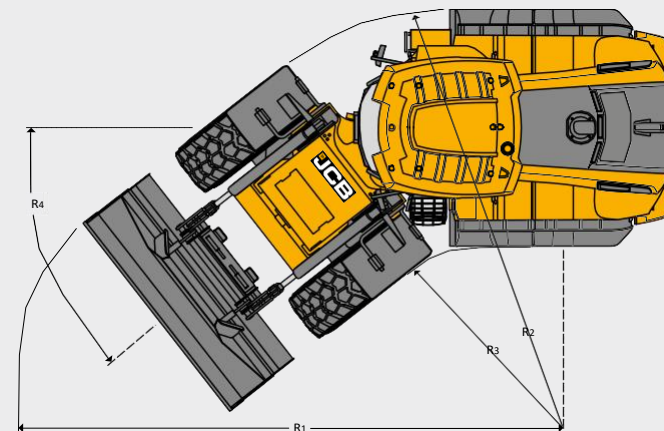
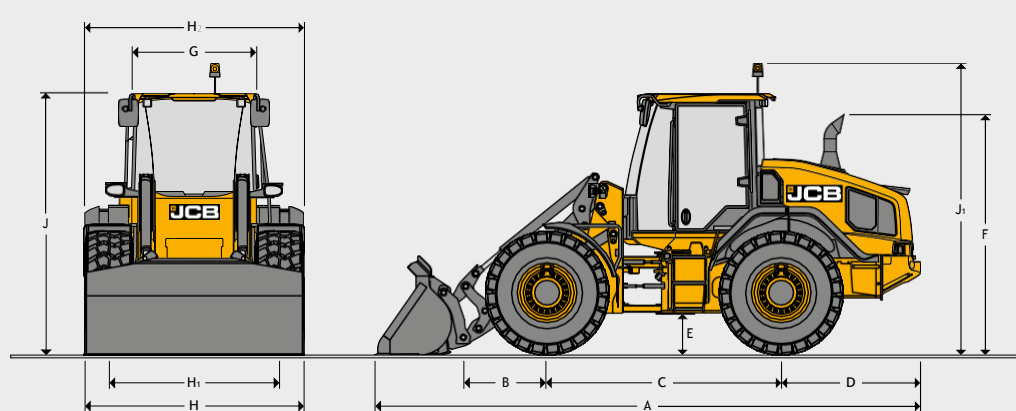

		419S	419S HL
A	Overall length	mm 6627	6877
B	Axle to pivot pin	mm 1004	1213
C	Wheelbase	mm 2850	2850
D	Axle to counterweight face	mm 1700	1700
E	Minimum ground clearance	mm 502	502
F	Height over exhaust	mm 2930	2930
G	Width over cab roof	mm 1540	1540
H	Maximum width over tyres	mm 2674	2674
H1	Wheel track	mm 2080	2080
H2	Maximum width over fenders	mm 2700	2700
J	Height over cab roof and lowered beacon	mm 3191	3191
J1	Height over raised beacon	mm 3559	3559
	Pin height (maximum)	mm 3700	3910
	Front axle weight	kg 4909	4998
	Rear axle weight	kg 6089	6061
	Total weight	kg 10998	11355

			419S	419S HL
R1	Maximum turn radius over shovel	mm	6138	6245
R2	Maximum turn radius over tyre	mm	5901	5901
R3	Inside turn radius	mm	3189	3189
R4	Articulation angle	degrees	35	35

419S Data based on machine equipped with quick hitch mounted 1.6 m<sup>3</sup> bucket with toe plates and 620/75R26 tyres.



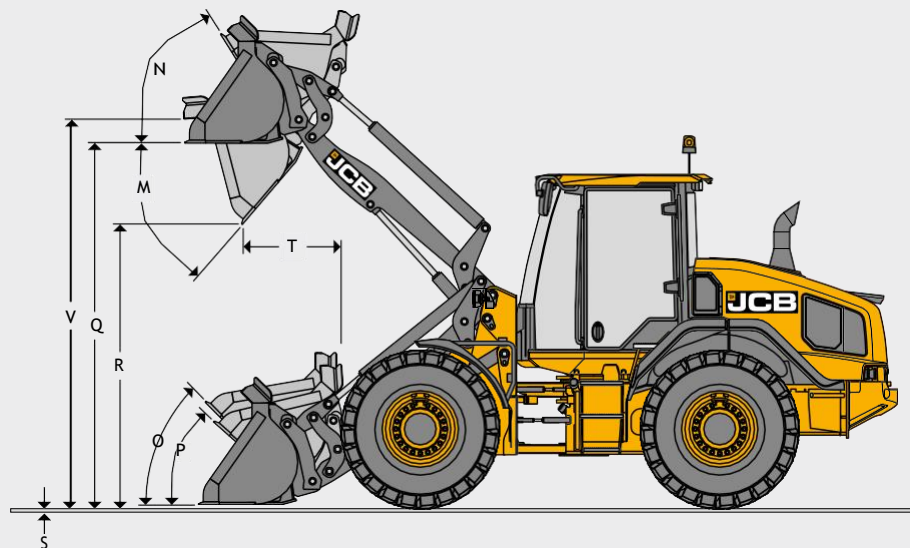

TYRE SIZE										
Tyre size	Manufacturer	Type	Rating	Operating weight (kg)	419S HT		419S HT HL		Dimensions	
					STL kg	FTTL kg	STL kg	FTTL kg	Vertical mm	Width mm
17.5R25	Michelin	XHA2	L3	-208	-141	-128	133	-121	-104	-262
17.5R25	Michelin	XSNOPLUS	L2	-148	-100	-91	-95	-86	-108	-260
20.5R25	Michelin	XHA2	L3	320	218	198	205	187	-68	-220
20.5R25	Michelin	XSNOPLUS	L2	236	161	146	152	138	-79	-240
500/70R24	Michelin	XMCL	-	-384	-260	-237	-246	-223	-129	-99
620/70R26	Michelin	CERAXBIB	-	-44	-30	-27	-28	-25	-57	30
750/65R26	Michelin	MEGAXBIB	-	296	201	183	190	173	13	210

#### LOADER DIMENSIONS 419S/419S HL

Model	419S HT				419S HL			
	Direct		Quickhitch		Direct		Quickhitch	
Shovel mounting	Direct		Quickhitch		Direct		Quickhitch	
Shovel type	General purpose				General purpose			
Shovel equipment	Tipped teeth	Reversible toeplate	Tipped teeth	Reversible toeplate	Tipped teeth	Reversible toeplate	Tipped teeth	Reversible toeplate
Shovel capacity (SAE heaped)	m <sup>3</sup>	1.6	1.6	1.6	1.6	1.6	1.6	1.6
Shovel capacity (struck)	m <sup>3</sup>	1.36	1.36	1.36	1.36	1.36	1.36	1.36
Shovel width	mm	2400	2400	2400	2400	2400	2400	2400
Shovel weight	kg	698	720	683	705	698	720	683
Maximum material density *	kg/m <sup>3</sup>	2296	2296	2243	2243	2149	2149	2099
Tipping load straight *	kg	8089	8089	7903	7903	7573	7573	7398
Tipping load full turn *	kg	7345	7345	7176	7176	6876	6876	6717
Payload *	kg	3673	3673	3588	3588	3438	3438	3359
Maximum breakout force	kN	93	93	86	86	84	84	77
M Dump angle maximum	degrees	50	50	50	50	46	46	46
N Roll back angle full height	degrees	58	58	58	58	61	61	61
O Roll back at carry	degrees	45	45	45	45	48	48	48
P Roll back at ground level	degrees	42	42	42	42	45	45	45
Q Load over height	mm	3477	3477	3492	3492	3689	3689	3702
R Dump height (45 deg dump)	mm	2750	2750	2715	2715	2997	2997	2958
S Dig depth	mm	18	18	0	0	35	35	20
T Reach at dump height	mm	840	840	898	898	897	897	960
V Pin height	mm	3700	3700	3700	3700	3910	3910	3910
Reach maximum (45deg dump) - horizontal arm	mm	1601	1601	1659	1659	1663	1663	1721
Operating weight (includes 75Kg operator and full fuel and DEF tanks)	kg	10807	10807	10998	10998	10868	10868	11059

Assumes machine is fitted with 620/75 R26 tyres, quickhitch and 1.6m<sup>3</sup> shovel with toe plate.

\* Based on 50% FTTL as defined in ISO 14397-1:2007.



ENGINE			
Type	Cummins		
Model	B - Series		
Capacity	litres	6.7	
Aspiration	Turbo Charged		
Cylinders	6		
Max gross power to SAE J1995/ISO 14396	kW (hp) @ 2200rpm	145 (195)	
Nett power to ISO 9249	kW (hp) @ 2000rpm	136 (183)	
Max torque	Nm @ 1300rpm	881	
Valves per cylinder	4		
Air cleaner	Cyclonic pre-filter with engine fan scavenge system		
Fan drive type	Hydraulically driven cooling fan		
Emissions	EU Stage V, USA T4F		

TRANSMISSION			
6 speed with lock up converter			
Make	ZF		
Model	6WG160		
		Forward	Reverse
1	kph	5.72	6.04 (non-locked)
2	kph	8.99	14.62
3	kph	13.87	33.94
4	kph	21.43	-
5	kph	32.18	-
6	kph	40 (48)*	-

Note: Figures are dependant on tyre configurations and vary slightly.

\* Over run option 21.527:1 and 48kph engine calibration, only when fitted with 620/75 R26 tyres and 750/65 R26 tyres.

AXLES	
Make	ZF
Model	MT-L 3075 II
Overall axle ratio	21.527 : 1
Rear axle oscillation	+/- 9 Degrees

All available with limited slip differential, open differential with auto-locking front.

ELECTRICAL SYSTEM		
System voltage	Amps	24
Alternator output	Amp hour	120
Battery capacity	Amp hour	2 x 110

HYDRAULICS		
Pump type	Variable displacement	
Pump 1 max. flow	l/min	180
Pump 1 max. pressure	bar	230
Hydraulic cycle times at full engine revs		
Arms raise (full bucket)	Seconds	3.86
Shovel dump (full bucket)	Seconds	1.53
Arms lower (empty bucket)	Seconds	2.4
Total cycle	Seconds	7.79

SERVICE FILL CAPACITIES		
Hydraulic system	litres	155
Fuel tank and auxilliary tank	litres	250
DEF Tank	litres	45

<b>STEERING</b>	Hydraulic power steering system and emergency steering.
<b>BRAKES</b>	Hydraulic power braking on all wheels. In-board mounted, sintered multi-plate disc brakes. Parking brake, electro-hydraulic disc type operating on transmission output shaft.

NOISE AND VIBRATION				
			Uncertainty	Measurement conditions.
Noise at the operator station	LpA	68 dB	+/- 1 dB	Determined in accordance with the test method defined in ISO 6396 and the dynamic test condition defined on 2000/14/EC.
Noise emission from the machine	LWA	104 dB	+/- 1 dB	Guaranteed equivalent sound power (external noise) determined in accordance with the dynamic test conditions defined in 2000/14/EC.
Whole body vibration	m/s <sup>2</sup>	0.53	+/- 0.11 dB	ISO 2631-1:1997 normalised to an 8h reference period and based upon a test cycle comprising of loader work (soil).
Hand-arm vibration	m/s <sup>2</sup>	<2.5	N/A	ISO 5349-2:2001 dynamic test conditions.



## LOADER DIMENSIONS WITH FORKS

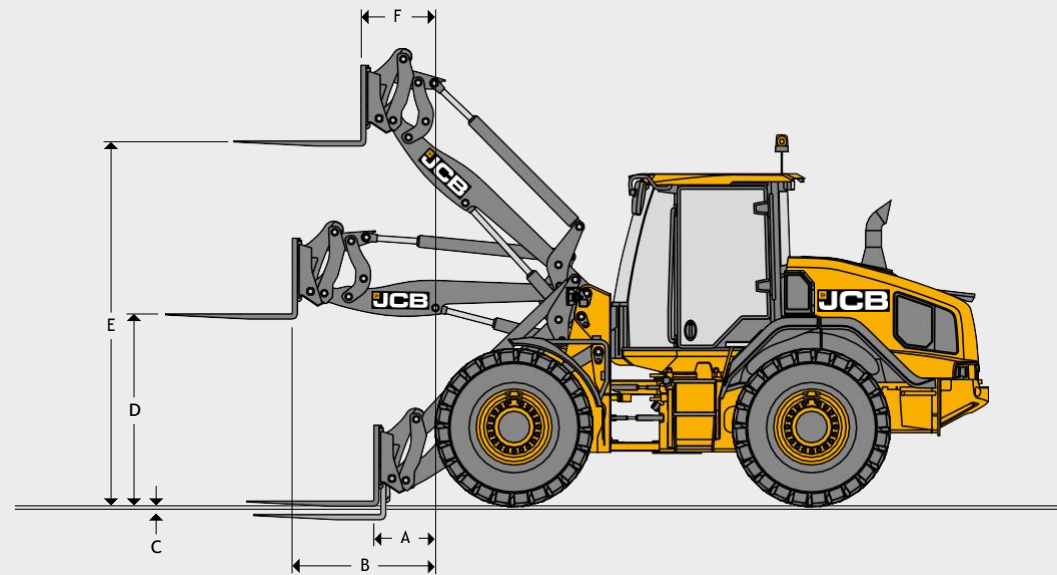

## LOADER DIMENSIONS WITH FORKS

		419S		419S HL	
		Parallel	Non parallel	Parallel	Non parallel
Fork carriage width	mm	1500	1500	1500	1500
Length of tines	mm	1220	1220	1220	1220
A Reach at ground level	mm	652	650	844	859
B Reach at arms horizontal	mm	1433	1421	1565	1571
C Top of tine above ground with arms down	mm	26	37	25	34
D Arms, horizontal height	mm	1852	1842	1852	1842
E Arms, maximum height	mm	3509	3499	3719	3709
F Reach at maximum height	mm	797	785	804	792
Tipping load straight	kg	7859	7905	7797	7841
Tipping load full turn (35°)	kg	7136	7178	7080	7120
Payload*	kg	5709	5742	5664	5696
Attachment weight	kg	435	430	435	430
Operating weight (includes 75kg operator and full fuel and DEF tanks)	kg	10929	10929	10990	10990

\*At the centre of gravity distance 600mm. Based on 80% of FTTL as defined in ISO 8313.

Machine is installed with 620/75R26 tyres, HT loader arm with non parallel links. Quickhitch, Fork and Frame 1500mm wide.



MATERIAL DENSITY		
Material	Loose density kg/m <sup>3</sup>	Fill factor %
Snow (fresh)	200	110
Peat (dry)	400	100
Sugar beet	530	100
Coke (loose)	570	85
Barley	600	85
Petroleum coke	680	85
Wheat	730	85
Coal bituminous	765	100
Fertiliser (mixed)	1030	85
Coal anthracite	1046	100
Earth (dry) (loose)	1150	100
Nitrate fertiliser	1250	85
Sodium chloride (dry) (salt)	1300	85
Cement portland	1440	100
Limestone (crushed)	1530	100
Sand (dry)	1550	100
Asphalt	1600	100
Gravel (dry)	1650	85
Clay (wet)	1680	110
Sand (wet)	1890	110
Fire clay	2080	100
Copper (concentrate)	2300	85
Slate	2800	100
Magnetite	3204	100

BUCKET CAPACITIES

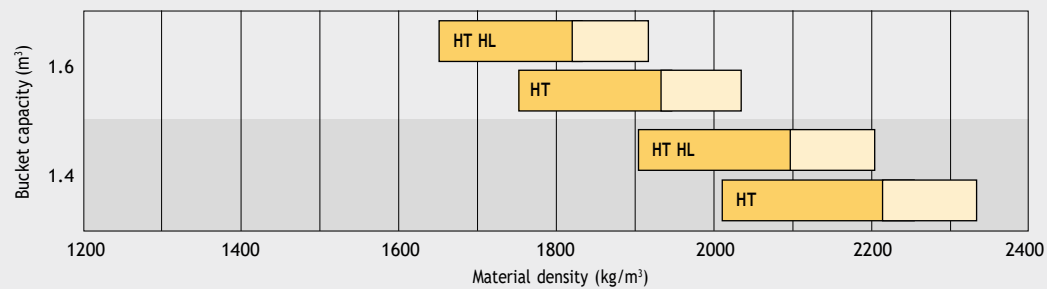

HT = Standard height arm    HT HL = High Lift arm    HT SHL = Super high lift arm

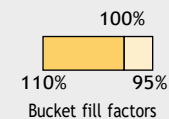



## EQUIPMENT

## SERVICE AND MAINTENANCE

5 year LiveLink telematics	●
Engine oil remote drain and fill	●
Grouped pressure test points	●
Lockable tool box	●
Lubrication points accessible from ground level	●

## ENGINE

Air cleaner - cyclonic pre filter with engine fan scavenge system	●
Automatically reversing cooling fan	●
Crankcase breather oil trap	●
DEF fluid	●
Fuel filter	●
Fuel pre-filter with water trap	●
Hydraulically driven cooling fan	●
Manual opening rear bonnet	●
-20° cold start	●
DOC/DPF/SCR Exhaust emission control	●
Waste gated turbo	●
Widecore radiator	●
Block heater (240V or 110V)	+

## ELECTRICAL

120 amp alternator	●
Amber rotating beacon	●
Twin amber beacons	+
Electrical adjustable mirrors	●
Heated mirrors	●
External battery isolator	●
Fold down beacon arm	●
Halogen front and rear working lights	●
Hazard warning lights	●
Integrated rear view camera	●
LED front and rear working lights	+
LED 360° working lights	+
Number plate light kit	●
Parking lights	●
Radio wiring and speakers	●
Rear fog light	●
Reverse alarm and light	●
Reversing object detection system	+
Road lights front and rear	●
Smart reverse alarm and light	+
Turn signals	●
White noise reverse alarm and light	+
Work lights on rear counterweight	●

## DRIVE TRAIN

6 speed transmission with lock-up torque converter	●
Operator controlled driving modes - Standard and Dynamic	●
Epicyclical wheel hub reduction	●
Fixed front axle	●
Gear kick down on loader control lever	●
Indicator glass for transmission oil level	●
Loader lever direction control	●
Neutral start	●
Open differential with automatic locking -100% (front axle only)	+
Limited slip differentials front and rear	+
Oscillating rear axle	●
Power-inch intelligent clutch cut off on footbrake (selectable)	●
Selectable automatic power shift	●
Steering column single lever shift control (direction and gear)	●
Speed limiter 48 km/h	+
Transmission cooler bypass	●

## BRAKE SYSTEM

Multi-plate wet disc brakes	●
Sintered brake pads	●
Dual circuit hydraulic power	●
Wheel speed braking	●
Parking disc brake on transmission output shaft	●
Electrical hydraulic park brake actuation	●
Trailer brake hydraulic supply	+

## OPERATOR STATION

Fully glazed cab	●
Air conditioning	●
Climate control	+
Single lever joystick	●
Multi-lever hydraulic controls	+
Proportional electro hydraulic auxiliary control	●
Deluxe heated air suspension cloth seat	●
Super deluxe heated and cooled air suspension half leather seat	+
Front roller blind	●
Rear roller blind	●
Cab air intake filter	●
Carbon cab air intake filter	+
2 x 12V in-cab power socket	●
24V in-cab power socket	+
Reversing camera (colour)	●
Fold away adjustable steering column	●
ROPS/FOPS safety structure	●
Interior light	●
Front primary display screen	●
Secondary A post display screen, rotary control menu interface	●
A post mounted membrane switches	●
Variable fan speed control on climatic control system	+

## OPERATOR STATION (CONTINUED)

50 mm seat belt	●
75 mm seat belt	+
Fire extinguisher (UK only)	+
Two speed intermittent front windscreen wipe/wash and self-park	●
Single speed rear windscreen wipe/wash and self-park	●
3 speed heater/demisting	●
LH and RH sliding opening windows	●
Floor mat	●
Cup holder	●
Steering wheel spinner knob	●
Internal rear view mirror	●
Tinted cab glass	●
Multi-media port (USB and 3.5mm)	●
Operator stowage	●
Laminated windscreen	●
Heated rear screen	●
Loader control isolator	●
Horn	●
Adjustable armrest	●
Removable storage rubber mats	●
In-cab coolbox (fridge)	+
Floor carpet	+

## FRONT PRIMARY DISPLAY

Warning lights	
Direction indicators	●
Master warning	●
High coolant temperature	●
Battery charging condition	●
Low fuel level	●
Engine oil pressure	●
Hazard lamps	●
Park brake state	●
Road lights	●
Main beam lights	●
Rear fog lights	●
Engine pre-heat	●
Brake system pressure	●
Differential lock	●
Low steering pressure	●
Buzzer alerts	
Engine air filter blocked	●
Diesel exhaust fluid (DEF)	●
Torque reduction in case of malfunction	●
Amber warning lamp	●
Stop engine	●

## EQUIPMENT (CONTINUED)

FRONT PRIMARY DISPLAY		RIGHT HAND SECONDARY DISPLAY		EXTERNAL EQUIPMENT	
Gauge display		Clock	●	Front and rear fenders	●
Engine speed	●	Climate control	●	Front removable mud flaps	●
Coolant temperature	●	Fan speed	●	Front wheel spray guards	●
Fuel level	●	In-cab temperature set	●	Full tyre width coverage fenders	●
LCD screen display		Machine hours	●	Automatic greasing system	+
Current gear	●	Rear view camera	●	Grease gun and cartridge	+
Stop engine	●	Fuel use	●	One piece manual opening bonnet	●
Torque reduction in case of malfunction	●	Time and date	●	Mesh air intake screens	●
Amber warning lamp	●	Auxiliary flow rate	●	Flexible bottom step	●
Diesel exhaust fluid (DEF)	●	Hydraulic oil temperature	●	Full width rear counterweight	●
Engine air filter blocked	●	Transmission oil temperature	●	Recovery hitch	●
Secondary steer system pressure	●	Machine settings screen		10,000kg hydraulic tow hitch with trailer brakes (12V or 24V electrics)	+
Torque lockup	●	Coolant temperature	●	10,000kg Rockinger tow hitch with trailer brakes (12V or 24V electrics)	+
Steer mode	●	Engine oil pressure	●	Lifting / tie down lugs	●
Ground speed	●	Air filter	●	Rear counterweight chevrons	+
Engine speed (numeric display)	●	Transmission sump temperature	●	Stainless steel exhaust stack	+
Clock	●	Transmission torque convertor temperature	●		
Hydraulic state	●	Hydraulic oil temperature	●	<b>PROTECTIVE EQUIPMENT</b>	
Smoothride system (SRS)	•	Park brake pressure	●	Rear grille guard	+
Beacon	●	Battery voltage	●	Safety strut loader arm	+
Front work lamps	●	Help display	●	Light guards	+
Rear work lamps	●	On-screen handbook	●	Rear belly guard kit	•
Heated rear screen	●			Articulation joint safety strut	•
Transmission sump temperature	●	<b>HYDRAULIC SYSTEM</b>			
Data screens		Smoothride system (SRS)	•	<b>OTHER EQUIPMENT</b>	
DEF level	●	Hydraulic quickhitch with in-cab isolation	+	High Lift loader end	+
Hydraulic oil temperature	●	Auxiliary ARV kit	+		
Torque convertor temperature	●	Auxiliary hydraulic service	●	<b>STANDARD</b>	●
Volume of fuel remaining	●	Twin auxiliary hydraulic service	+	<b>OPTIONAL</b>	+
Total fuel used (resettable)	●	Single piston pump with priority steer	●		
Instantaneous fuel use	●	Emergency steer back-up	●		
Average fuel use (resettable)	●	JCB biodegradable hydraulic oil	+		
Current date	●	Electronic hydraulic isolation	●		
Machine hours	●	Automatic boom kick-out. Detent	●		
Trip distance (resettable)	●	Automatic bucket positioner	●		
Hours to service	●	Front loader float	●		
Daily checks		Indicator glass for hydraulic oil level	●		
Engine oil level	●	Hydraulic oil cooler	●		
DEF level	●				









**ONE COMPANY, OVER 300 MACHINES.**

Your nearest JCB dealer

**AGRARTREND, s.r.o.**  
 Komárňanská cesta 10844  
 940 01 Nové Zámky  
 Mobil:+421 917 226 244  
 E-mail: pm@agrartrend.eu

**Wheel Loader 419S**

Gross engine power: 145kW (195hp) Operating weight: 10998kg  
 Full turn tipping load: 7176kg Standard shovel capacity: 1.6m<sup>3</sup>

JCB Sales Limited, Rocester, Staffordshire, United Kingdom ST14 5JP.  
 Tel:+44 (0)1889 590312 Email: salesinfo@jcb.com  
 Download the very latest information on this product range at: [www.jcb.com](http://www.jcb.com)

©2009 JCB Sales. All rights reserved. No part of this publication may be reproduced, stored in a retrieval system, or transmitted in any form or by any other means, electronic, mechanical, photocopying or otherwise, without prior permission from JCB Sales. All references in this publication to operating weights, sizes, capacities and other performance measurements are provided for guidance only and may vary dependant upon the exact specification of machine. They should not therefore be relied upon in relation to suitability for a particular application. Guidance and advice should always be sought from your JCB Dealer. JCB reserves the right to change specifications without notice. Illustrations and specifications shown may include optional equipment and accessories. The JCB logo is a registered trademark of J C Bamford Excavators Ltd.

